

TECHNICAL DATA Cogeneration Unit
IET BIO 190 V01_50



Module: BIO 190 V01_50

Engine: 2876 LE 302



Foto: IET 190 with canopy, lateral doors opened

El. Output: 190 kW
Th. Output: 225 kW

NOx < 500 mg/Nm³
CO < 650 mg/Nm³
NMHC < 150 mg/Nm³

TECHNICAL DATA CHP MODULE

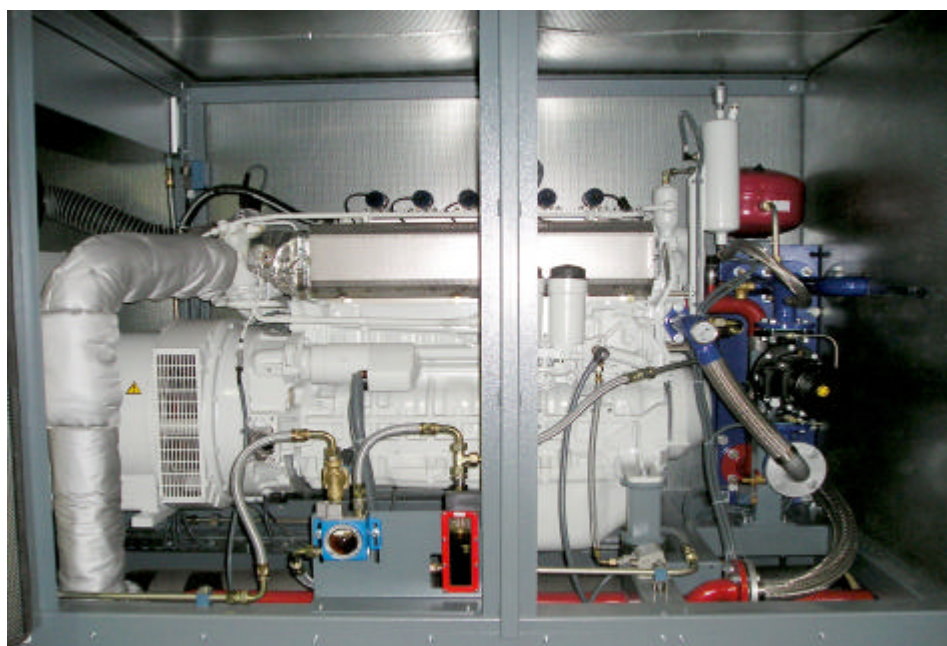
IET BIO 190 V01_50



Technical main data

fuel gas type	Landfill, Digester and agricultural Biogas			
gas LHV	kWh/m ³ n	6		
emissions: NOx / CO / NMHC	mg/m ³ n	500	/ 650	/ 150
rated speed	1/min	1500		
starter	kW / VDC	6,5	/ 24	
power	ISO-Standard power ICN			

Engine type

number of cylinders / configuration		6	/	line
bore / Stroke	mm	128	/	166
displacement	dm ³	12,82		
compression ratio	:1	11		
average piston speed	m/s	8,3		
lube oil filling capacity	dm ³	40		
lubrication oil consumption at full load ca.	g/kWh	0,5		
jacket water quantity motor (+ turbo charger)	dm ³	16		
hot water temperature inlet / outlet max.	°C	80	/	86
cooling water flow rate	m ³ /h	18,3		
LT mix gas cooling water temperature engine in- / out max.	°C	45	/	48
LT mix gas cooling water flow rate	m ³ /h	5,2		

Alternator

manufacturer / type		Stamford	/	HCI 444 D 2
voltage / frequency	V / Hz	400	/	50
alternator efficiency (at cos phi = 1,0)	%	95,5		

Load

mechanical power acc. ISO 3046/1	%	100	75	50
average actual pressure at nom. load and nom. speed	kW	180	150	100
exhaust gas temperature at full load	bar	12,48		
exhaust gas mass / volume flow, wet	°C	520		
combustion air mass / volume flow - ISO 3046/1	kg/h / m ³ n/h	956	/	746
	kg/h / m ³ n/h	857	/	664

Energy balance

(thermal output: tolerance ± 8%)

electrical output (at cos phi = 1,0)	kWel	190	143	95
thermal output cooling water + oil	kW	115	88	68
exhaust gas, cooling to 150°C	kW	110	84	63
HT Mixture at water temperature 80 °C	kW	17	6	6
radiation heat motor plus alternator	kW	16		
residual heat	kW	15		
total usable thermal power	kW	225	172	131
power input (tolerance + 5%)	kW	493	375	269
specific gas consumption	kW / kW	2,74	2,50	2,69
electrical efficiency	%	38,54	38,13	35,32
thermal efficiency	%	45,64	45,87	48,70
total efficiency	%	84,18	84,00	84,01

Ambient conditions

air flow rate (incl. combustion air) ?T = 10 °K	m ³ n / h	12.900		
suction temperature min. / design	°C	15	/	25
reference installation altitude to mean sea level	m	100		
disability related to installation altitude at mean sea level	%	0,7	/	0,5
max exhaust gas back pressure after engine	mbar	50		
max. suction resistance at air filter	mbar	10		
gas pressure min / max at gas inlet to gas train, fixable	mbar	50	/	100
max. admissible fluctuation	mbar/30s	3		
starter battery 24V, required capacity	Ah	143		
module dimensions L x W x H	mm	3.600	1.300	2.200
module weight dry / filled	kg	3.900	/	3.980

Sound emissions (in 1 m)

frequency range		HZ	31,5	63	125	250	500	1000	2000	4000	8000
engine	104,3 dB(A) ± 3	dB		66,2	78,2	88,7	95,2	98,5	99,0	96,4	93,4
exhaust gas	139,3 dB(A) ± 3	dB		133,0	119,8	114,9	126,9	137,3	125,8	121,0	108,0

TECHNICAL SCHEME CHP MODULE

IET BIO 190 V01_50

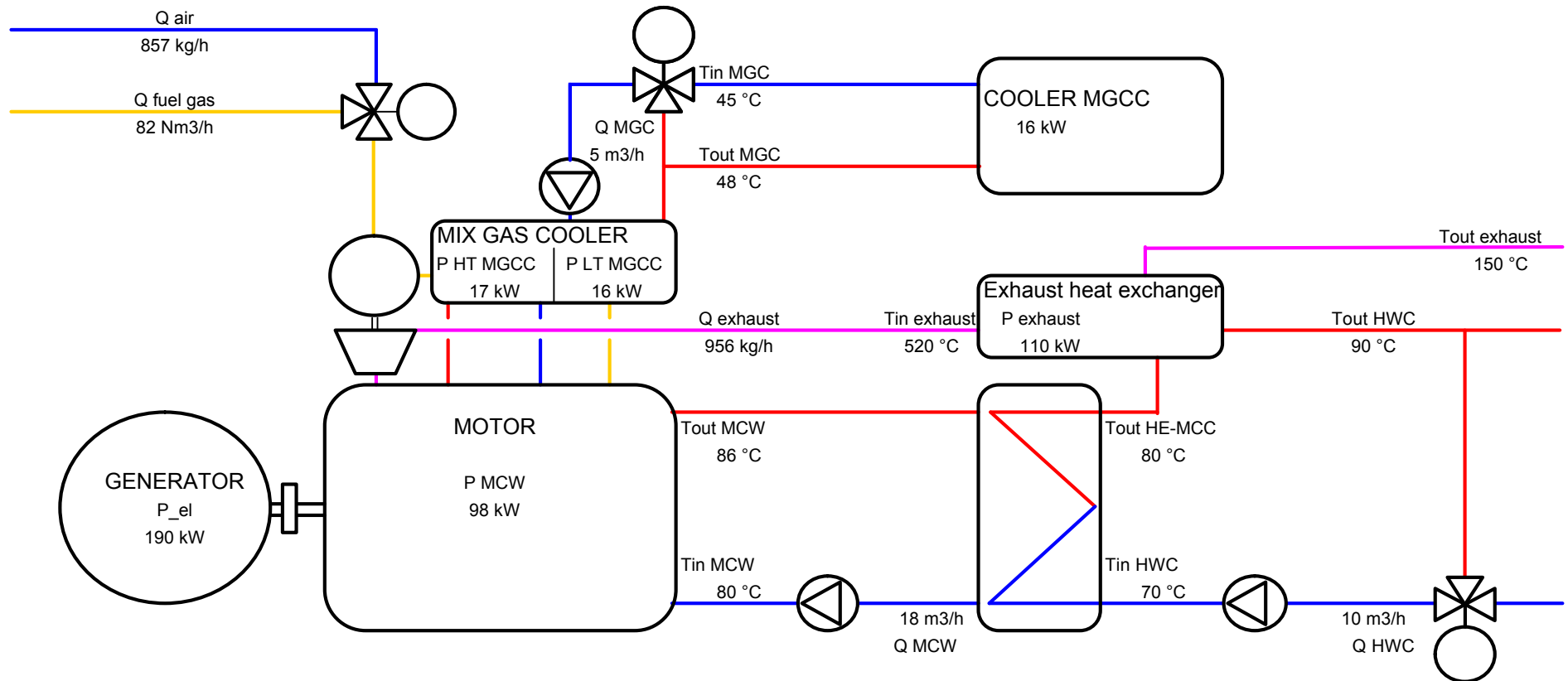

P mech.	180	kW
P el.	190	kW
P genset th.	115	kW
P module th.	225	kW
Eta el.	38,54	%
Eta gen th.	45,64	%
Eta total	84,18	%
Erstellt: C. Köllner	10.10.2008	

NOx	500	mg/Nm ³
CO	650	mg/Nm ³
NMHC	150	mg/Nm ³
LHV gas	6,0	kWh/Nm ³
Q gas	82	Nm ³ /h
Q air	857	kg/h
Q exhaust	956	kg/h
Q vent-air	12.000	Nm ³ /h

module	IET BIO 190 V01_50	
motor	E 2876 LE 302	
generator	HCI 444 D 2	
length	3.600	mm
height	1.300	mm
width	2.200	mm
weight dry	3.900	kg
weight wet	3.980	kg

OUTPUT / EFFICIENCY Cogeneration Module IET BIO 190 V01_50



Output in relation to load

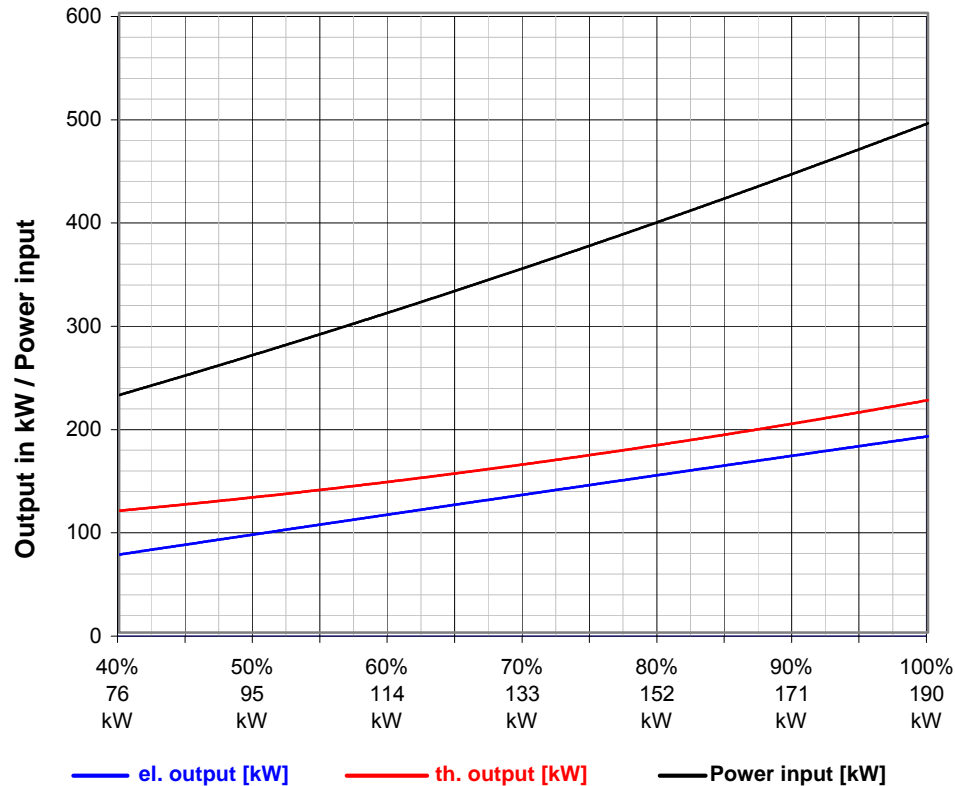

Efficiency in relation to load

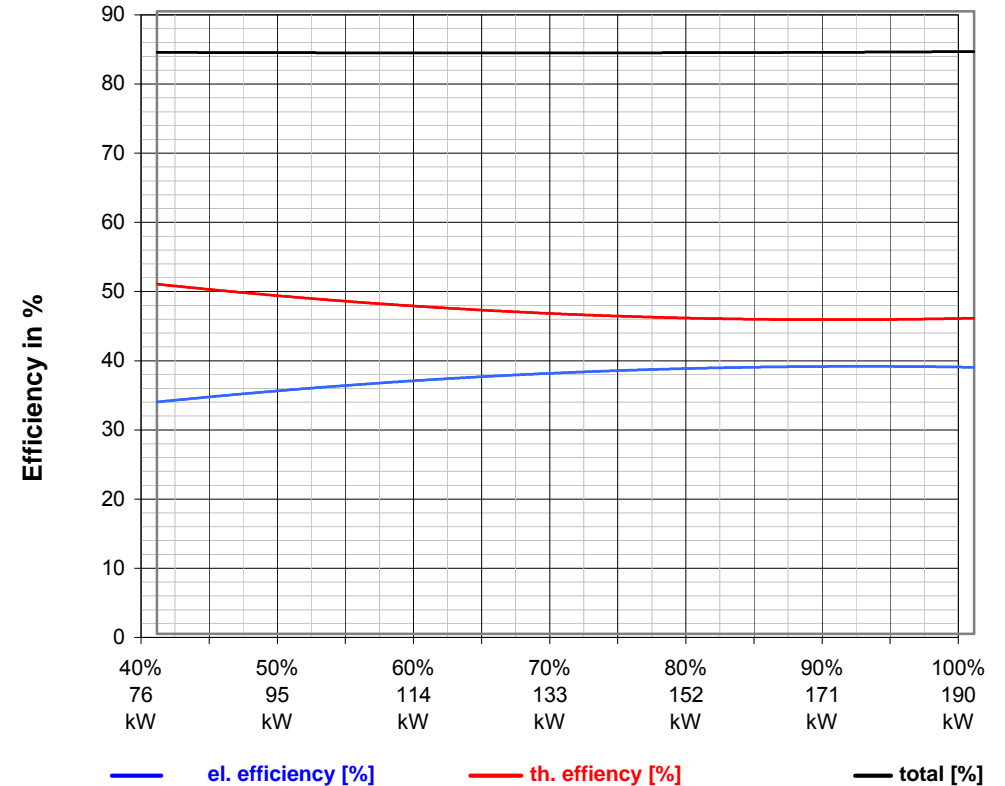

P mech.	180	kW
P el.	190	kW
P genset th.	115	kW
P module th.	225	kW
Eta el.	38,54	%
Eta gen th.	45,64	%
Eta total	84,18	%
Erstellt: C. Köllner 10.10.2008		

NOx	500	mg/Nm ³
CO	650	mg/Nm ³
NMHC	150	mg/Nm ³
LHV gas	6,0	kWh/Nm ³
Q gas	82	Nm ³ /h
Q comb.-air	857	kg/h
Q exhaust	956	kg/h
Q vent-air	12.000	Nm ³ /h

module	IET BIO 190 V01_50	
motor	E 2876 LE 302	
generator	HCI 444 D 2	
length	3.600	mm
height	1.300	mm
width	2.200	mm
weight dry	3.900	kg
weight wet	3.980	kg